

M12x1.75 THREAD x 1.00 DEEP  
C'BORE DIA. .492 x .236 DEEP

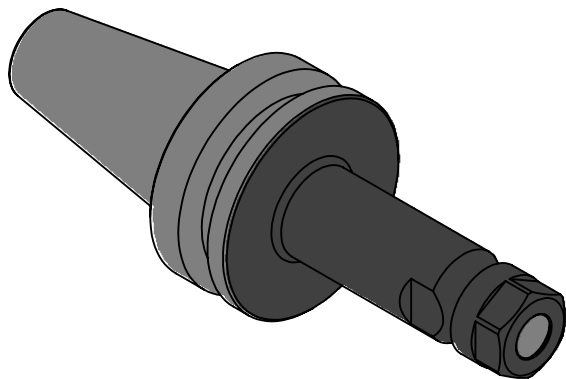
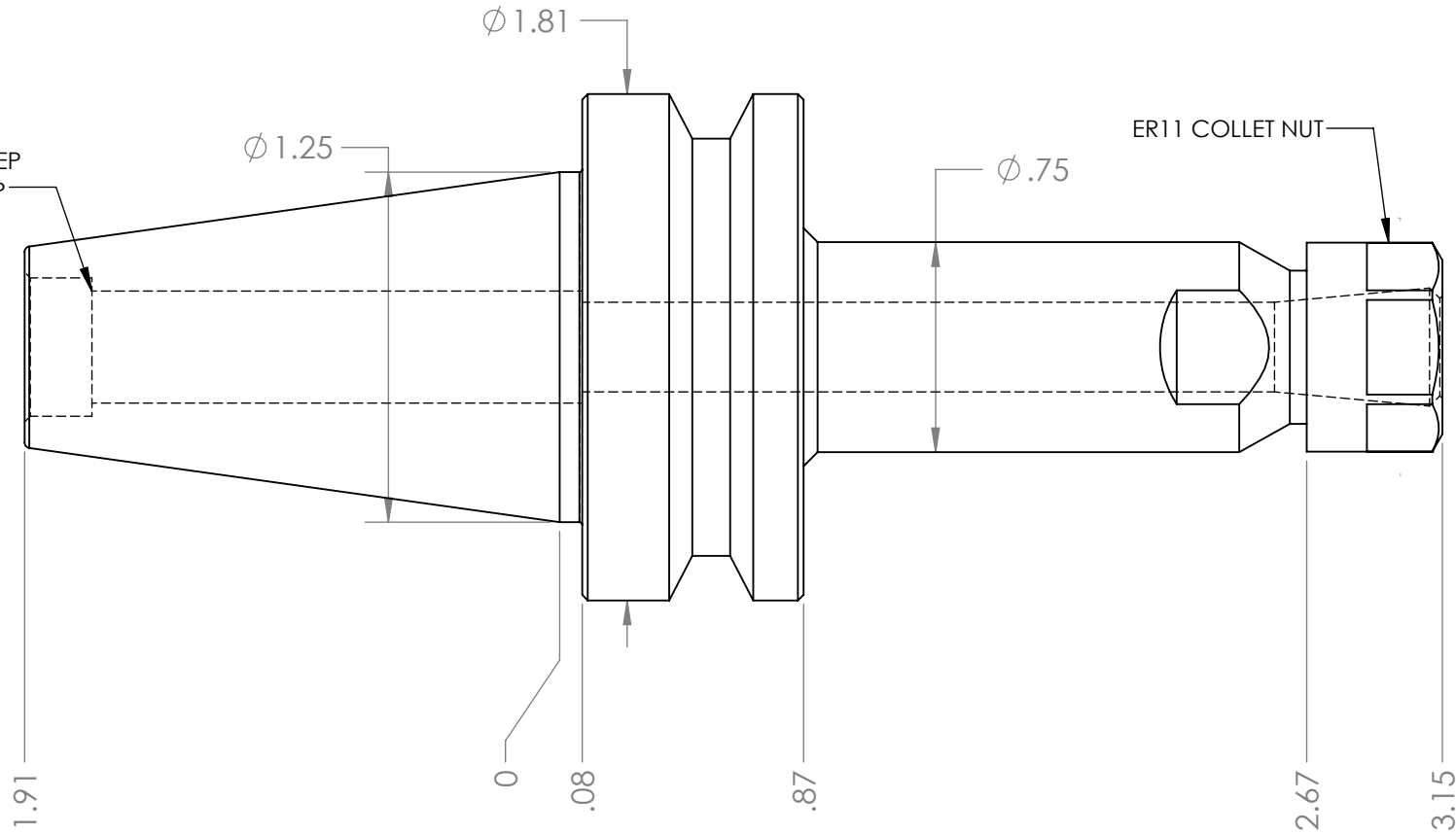

NOTES:

WORKS ON ALL BT30 MACHINES  
TAKES ALL ER11 COLLETS FROM .020"-.276"  
USES WRENCH PART # ER11 WRENCH (NOT INCLUDED)  
FOR MORE PRODUCT DETAILS PLEASE GO TO MARITOO.COM  
AND SEARCH ITEM # LISTED ON THIS PRINT

**MARITOO**

WWW.MARITOO.COM

ITEM# **BT30 ER11-80-W**

Made in USA